



एक कदम स्वच्छता की ओर



Engineering Growth

HEMAN 175

SKID STEER LOADER

ONE MAN ARMY



VERT EQUIPMENT
PRIVATE LIMITED



SKID STEER LOADER

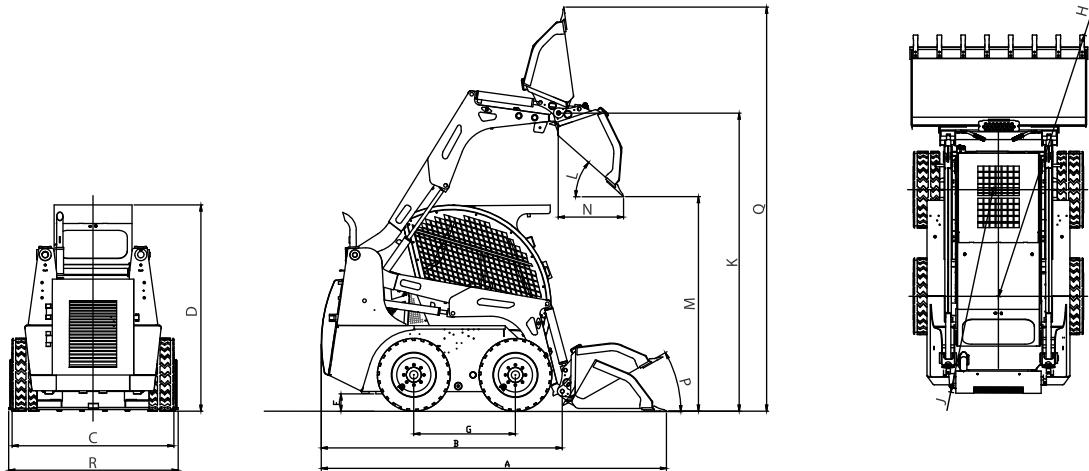

DIMENSIONS

	mm/deg
A - Length with bucket	3475
B - Length without bucket	2570
C - Width over tyres	1650
D - Overall Height	2100
E - Ground clearance	195
F - Departure angle rear	26
G - Wheelbase	1023
H - Turning radius rear corner	2110
J - Turning radius bucket corner	2680
K - Pin height	3022
L - Dump angle	40
M - Dump Height	2180
N - Reach at dump height	642
P - Roll back angle at ground	30
Q - Max reach at full height	4000
R - Bucket width (Standard)	1708

FEATURES

Multi-disc parking brakes
Gear drive
Front cab access
Fuel water trap
Hydraulic parallel lift
Adjustable seat
Instruments audio/visual
Instruments
Dual element air cleaner
Chassis-rigid fully welded high tensile steel structure
Roof window for enhanced operating visibility.
Rear window for emergency exit.
Heavy duty gear boxes with slip-free gears.
Axles of high ductile forgings, self lubricating.

Mechanical hitch for quick change of attachments.
Ergonomically designed seat, user friendly controls.
Visual and audio warning to prevent system failures.
Adequate inbuilt safety measures for operator/machine.
Hydraulic tilt back cabin for maintenance ease.
Easy to maintain and service with normal tools.

TRANSMISSION

Hydrostatic 4X4 independent drive through
Tandem variable displacement axial pumps
Fixed displacement low speed high torque motors

Final drive through positive gear drive (Train)

TYRES

Front/ rear	10X16.5-10/8PR
Max. travel speed	13 kmph

SPECIFICATION

SAE Operating weight	2900 Kgs
Standard bucket capacity	0.46 cu m.
Time to raise lift arms fully	3-5 Sec.
Breakout force-bucket	18850Nm
Breakout force-lift arm	14450Nm

STANDARD FEATURES

Auxiliary hydraulics
Cab - swing up
Tubeless tyres
Key stop
Lift arm stop
Lifting eyes
Working light
Quick hitch
Roof window
Safety Seat belt
Air Cleaner clog warning indicator
Battery charge
Charge pump pressure
Coolant temperature gauge
Engine oil pressure
Fuel level gauge
Hour counter
Hydraulic oil temperature gauge
Cabin light
Rear window for emergency exit
Hydraulic clog indicator
Fuel clog indicator
Cab with front door lock
Rear view mirrors
Wiper motor with wiper blade
Cabin fan
Head lights with side indicators
Tool kit
4 chamber tail lamps

HYDRAULICS

Engine driven gear pump with valve block, twin arms lift cylinder with end cushion and bucket cylinders.	
Flow (Liters per min)	80
Working pressure (bar)	175

ELECTRICALS

12 volts negative earth system with battery isolator	
Battery	130AH
Low maintenance alternator	35Amp
Starter motor	12 V

BRAKES

Service brake: Hydraulically activated and released multi plate Fade free breaks from integral part of drive motors.
Parking Brake: Electrically activated

CAPACITIES

Fuel tank	62 Liters
Engine lub oil	13 Liters
Engine coolant	12 Liters
Transmission	16 Liters
Hydraulic system	70 Liters

PERFORMANCE

Rated operating capacity	600-750 Kgs
Tipping load	1200 Kgs

ENGINE

BS III Model
Simpson S433 Industrial BS III, 35.79kW/ 48HP / 48.67PS @2200rpm 4 Cylinder, Liquid Cooled, Diesel Engine, Naturally Aspirated

ATTACHMENTS

6 IN 1 Bucket
Sweeper collector
Ripper tooth
Backhoe
Excavator Bucket: 300mm,450mm,600mm
Ditch Cleaning bucket.
Pallet Forks
Industrial grapple
Rock breaker
Snow blower
Steel tracks(Track over tyres)
Rubber tracks (Track over tyres)
Post hole borer / Auger
Shredder
Snow Blade
Stump Grinder
Trencher
Side Tip Bucket
High Tip Bucket

OPTIONAL

Heavy duty tyres/ Solid tyres -Tubeless
Buckets: Varying capacities upto 0.65 cum limited to machine rating operating capacity.
Servo Variant also available

Note : All are variable within ± 1.5%. Vert Equipment Pvt Ltd. reserves the right to change specifications without prior notice.

VERT EQUIPMENT PRIVATE LIMITED

(Formerly known as Vectra Advanced Engineering Pvt. Ltd.)

Factory : Plot No. 22 , Udyog Vihar, Greater Noida, Gautam Budh Nagar, Uttar Pradesh - 201 306, India.
Phone : +91-120-474 6300, Fax : +91-120-474 6376, E-mail : vectradel@vertepl.com, marketing@vertepl.com

Regd. Office : Vectra House, No. 15, 1st Main Road, 6th Cross, Gandhinagar, Bengaluru - 560 009, India.
Phone : +91-80-4129 0011, Fax : +91-80-4151 6422,

Email : marketing@vertepl.com

www.vertepl.com